

# INSTRUCTION

## METERING VALVE

MODEL. KGK-400 series



### WARNING

Prior to operating this pump, be sure to read this operation manual for safety. After reading the manual, please keep it at hand any time for your quick reference.

**YAMADA CORPORATION**

---

## [Introduction]

---

This instruction manual contains important safety information and operational instructions.

Read this manual before installation, operation, maintenance, and repair.

Do not use the product without reading this manual. Thoroughly read and understand all of the product information, safety information, and warning information in the manual.

If you have any questions, please contact the store you purchased the product or our business office.

---

## [For Safe Operation]

---

According to the hazard level, all safety notes in this manual are classified into “DANGER”, “WARNING”, and “CAUTION”.

Be sure to read and observe the safety notes to ensure safety and correct use of this product.

---



indicates a potentially hazardous situation which, if not avoided, **WILL** result in death or serious injury.



indicates a potentially hazardous situation which, if not avoided, **COULD** result in death or serious injury.



indicates a potentially hazardous situation which, if not avoided, could result in injury or property damage.

---

## — Table of Contents —

[Introduction].....	1
[For Safe Operation].....	1
1. Precautions on Use .....	2
2. Product Description .....	3
3. Principle of Operation.....	4
4. Installation and Connection .....	5
5. Troubleshooting .....	7
6. Disassembly and Assembly.....	9
7. Product and Part List for Grease Metering Valve .....	12
8. Product and Part List for Grease Metering Valve with Sensor.....	18
9. Product and Part List for Adhesive Metering Valve.....	25
10. Limited Warranty .....	29

## 1. Precautions on Use

The following warnings and cautions are very important. Be sure to observe them.

[Operating condition]



### CAUTION

- For your safety, read and understand all information provided in this manual. If you have lost or damaged your instruction manual, please contact us or our distributor to place an order.
- Never let anyone operate this unit without understanding this manual.

[Installation and piping]



### CAUTION

- Before maintenance operation, be sure to stop air, and release the internal pressure (both air and material) of the product.
- Immediately stop using the product if there is any danger or defect. Be sure to eliminate the cause and confirm safety before restarting.
- Follow the safety instructions for installation and be sure to use appropriate piping material and size to avoid leakage and damage.

[Operating method]



### WARNING

- Understand this manual completely before operating the machine. Operators and maintenance personnel are required to read this manual thoroughly before operating or servicing. Do not handle this machine without understanding the instructions.
- Do not handle unspecified material with this product. It may cause a product failure.
- Do not use this product for improper purposes.

[Disassembly, maintenance and inspection]



### WARNING

- Shut off air supply to the product and remove residual pressure completely BEFORE disassembling.
- Alternating the unit may result in personal injury or product malfunction. Please do not try to alter, modify, or change the machine.

[Shutdown and storage]



## CAUTION

- When leaving the product unused for a long time (more than a week) or shutting it down:
- remove material inside completely and wash the product and
- release material supply pressure.

## 2. Product Descriptio

KGK metering valves are able to apply metered shots of media such as greases and adhesives. By replacing a built-in metering cylinder, KGK metering valves cover metered shot volumes between 0.5 mL to 50 mL.

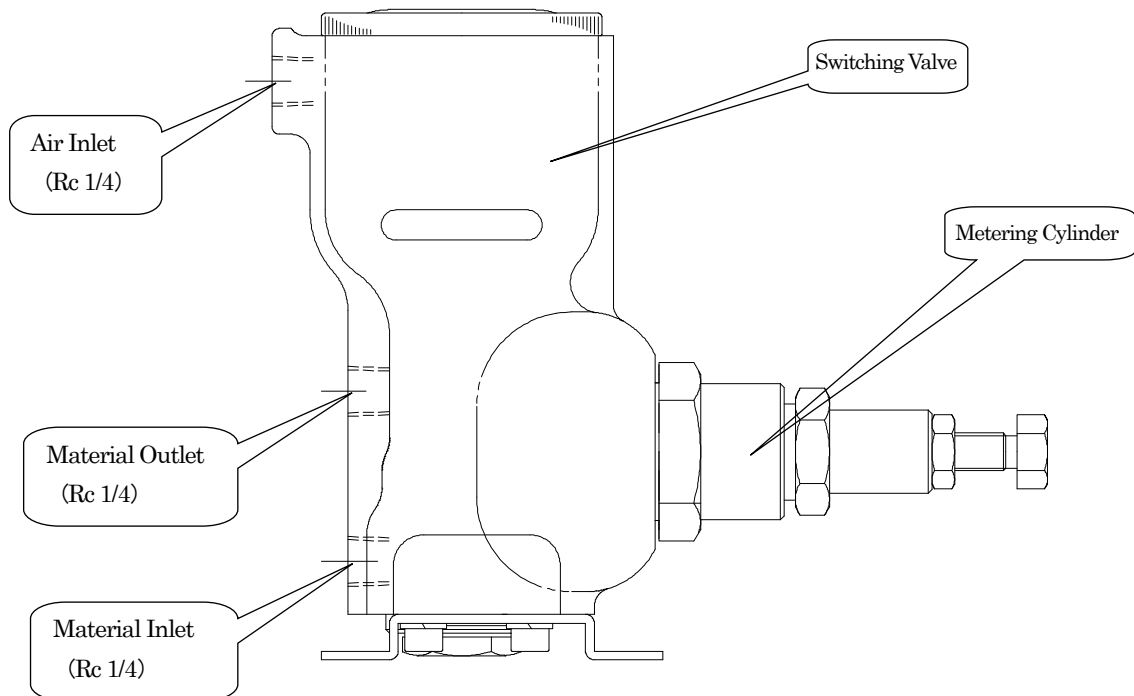

## CAUTION

- In grease metering valves, NBR and urethane rubber are used in seal parts. Do not try to handle any material incompatible with these parts. If need arises, use adhesive metering valves which use seal parts made with fluorine resin.
- Release residual pressure inside the valve BEFORE maintenance, inspection, and repair.

### 3. Principle of Operation

#### 3-1 Standby

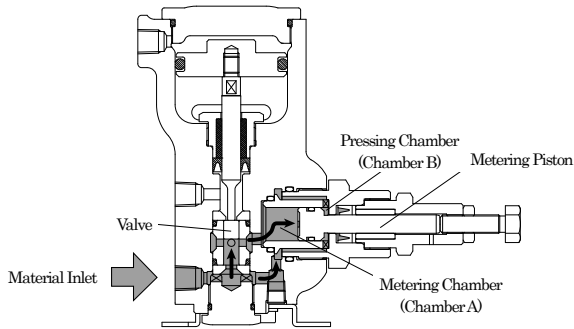

Material delivered to the supply channel lifts up the valve with its pressure and presses it against the seat on the discharge side. While the valve is blocking material flow to the discharge port, Chamber A (metering chamber) becomes filled with material.

At the same time, material, under pressure from a supply pump, is constantly being delivered to Chamber B (pressing chamber) at the back of the metering piston through a bypass groove around the valve.

At this time, when the same pressure is applied over both Chamber A and B, the force acting on Chamber A is stronger due to a difference of pressure receiving area.

Thus, the metering piston is pushed to Chamber B and comes to a stop against the head of adjustment screw.

#### 3-2 Discharge

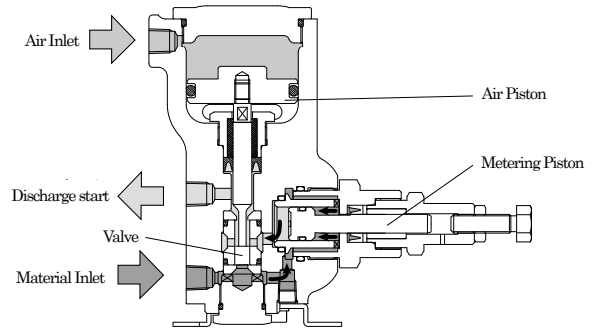

When the air piston is pushed down by supplied air, the material inlet is closed and the material outlet opens. Then, material pressure in Chamber A decreases with material flow from the chamber. At the same time, regardless of valve condition, material, under pressure from a supply pump, is constantly supplied to Chamber B through the bypass groove. Accordingly, the metering piston starts moving forward and material in the metering chamber is discharged.

#### 3-3 Completion

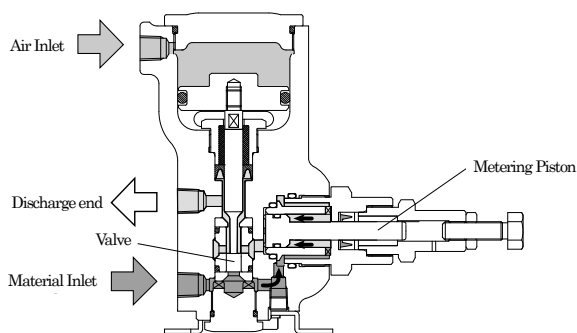

The metering piston pushes out all material inside the metering chamber and comes to a stop against the end wall. Discharge is now complete. Even when valve is open toward the discharge side, material other than a metered shot will not flow out.

#### 3-4 Recharge

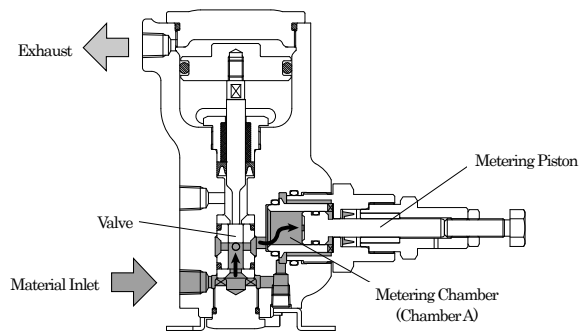

After supplied air is discharged, the valve is lifted up by material pressure and again pushed against the seat on the discharge side to close the material outlet. Material flows into the metering chamber as pushing the piston back. Residual material in Chamber B flows back through the bypass groove to Chamber A, being mixed together with newly delivered material.

## 4. Installation and Connection

 <b>CAUTION</b>	
<ul style="list-style-type: none"> <li>- Do not screw the adjusting bolts in when the metering valve is in the state of standby.</li> <li>- Do not too strongly screw the metering cylinder to the switching valve.</li> <li>- Regarding the fluid supply pressure to the metering valve, adjust the pressure within the applicable range from 2 - 20 MPa, so that the metering valve will accurately work.</li> </ul>	

### 4-1 Selection of metering valve

Select an appropriate metering valve by referring “Cylinder Size” in the table. The size of a cylinder should be closest to your desirable amount of a shot. If you want to have 0.3 mL and 2mL shots using the same metering valve, provide a 1mL cylinder for 0.3 mL shots and a 3 mL cylinder for 2 mL shots. Replace a cylinder depending on the amount you want to dispense.

Especially where an accurate shot is required, it is not recommended to use a large cylinder for a small amount of shot.

\* A metering error varies among materials. Usually, it is between plus or minus 1.5 - 2%.

Cylinder Size (mL)	Setting Range (mL)
0.5	0.05-0.5
1	0.2-1
3	0.3-3
5	2-5
10	4-10
20	8-20
50	15-50

### 4-2 Installation

Install your metering valve as close as possible to the equipment or its inlet port you are going to work on. The longer the connection is, the more the discharge amount from the outlet varies.

### 4-3 Connection

#### ① Material Inlet

Connect the material inlet (Rc 1/4) of your metering valve and a material supply pump with a pipe or hose.

 **CAUTION:** Material supply pressure to the metering valve depends on viscosity of material. The working pressure of K GK metering valves ranges from 2 MPa to 20 MPa. Set the lowest air pressure at which your metering valve works properly.

#### ② Material Outlet

Connect a metal pipe such as copper or steel between the outlet (Rc 1/4) of the metering valve and dispensing equipment such as a nozzle. In this time, keep the pipe as short as possible.

 **CAUTION:** Avoid using a soft material like a nylon tube for connection. Metered shots will be variable in amount. In case that you have to use a flexible tube or pipe, attach an automatic valve to the pipe (tube) end to obtain accurate shots equal to a metal pipe.

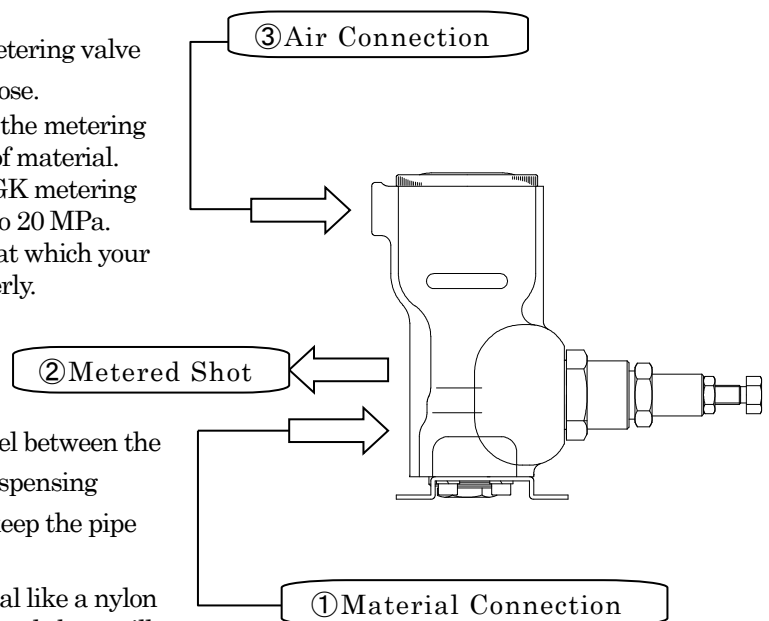

- \* When connecting the outlet of your valve to multiple nozzles, install 686441 Restrictor respectively close to each nozzle. Adjust the restrictors to make each of metered shots equal amount.
- \* When applying a metered shot at a constant length, attach 686442 Automatic Valve (sold separately) or 686437 Automatic Flow Gun (sold separately) to a material outlet.

### ③ Air Inlet

Connect an appropriate air valve such as 3 port solenoid valve or mechanical valve.

 **CAUTION:** Air should be supplied through an air filter, lubricator, and air regulator. Set the air pressure between 0.4 MPa to 0.5 MPa.

 **WARNING:** Do not set the air pressure over 0.7 MPa.

### 4-4 Precaution for initial use

When you use the metering valve for the first time including the first use after repair, be sure to completely remove trapped air from a material supply pump, hose, pipe, and metering valve.

Disconnect a pipe attached on the material outlet and run the metering valve to remove trapped air. Repeat this procedure until all air is removed completely. Confirm that the valve is securely closed BEFORE reconnecting a pipe to the outlet.



## PRECAUTION FOR USE

- Be sure to shut off the air supply to a supply pump and set the material pressure (primary pressure) to zero. Leaving a metering valve under pressure will be a cause of material leak or some other problem.
- Once a metered shot is dispensed, be sure to put the valve back to the standby condition.
- Avoid inclusion of air in material as much as possible.  
Trapped air in material will be compressed through a pump, pipe, hose, and metering valve and expand when material is dispensed. As a result, the metering valve will have difficulty stopping discharge and thus it may seem to be leaking. Also, each shot will be variable in amount.  
Furthermore, material will gush out of the outlet and splatter around.  
Be sure to release air completely when using the product for the first time or after replacing a metering cylinder.
- Do not use material which contains dirt and dust. Seal parts will be damaged, causing a material leak.
- In such problems that material continuously flows out from the outlet or a shot is variable in amount, it is necessary to figure out whether a defect is caused by malfunction of the valve or some other equipment. Carry out an operation test on your valve independently and investigate the condition of the material outlet.
- Due to long term use, material which couldn't be stripped off by a seal builds up little by little. This is not always abrasion of a seal part. It is important to wipe off seal parts after use or periodically to extend the life of these parts.

## 5. Troubleshooting

### 5-1 Troubleshooting (metered shot)

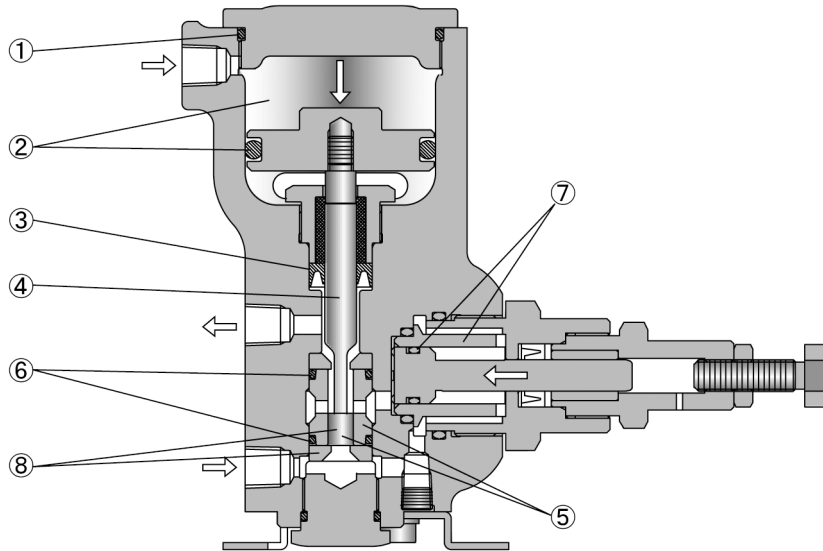

#### <Problem>

- Air leak occurs.
- Material leak occurs in air cylinder.
- Material still flows out after a metered shot has been dispensed.

#### <Possible Cause>

- ① O ring is damaged or worn out.
- ② O ring is damaged or worn out or cylinder inside is damaged.
- ③ Packing is damaged or worn out.
- ④ Piston rod is damaged.
- ⑤ Sleeve inside or valve is damaged
- ⑥ O ring is damaged or worn out.
- ⑦ O ring is damaged or worn out or cylinder inside is damaged.
- ⑧ Valve or valve seat is not closed completely.  
(Thin part of piston rod is deformed and rod length has become shorter.)

#### <Solution>

- Replace with a new one.
- Replace with a new one.
- Replace with a new one.
- Replace with a new one.
- Replace with a new one.
- Replace with a new one.
- Replace with a new one.



## CAUTION

- The life of a U-packing is reduced if the sleeve inside is severely damaged or clearance between the piston and rod has become too much. At the time of replacing the U-packing, be sure to check the sleeve and piston as well.

## 5-2 Troubleshooting (return or waiting)

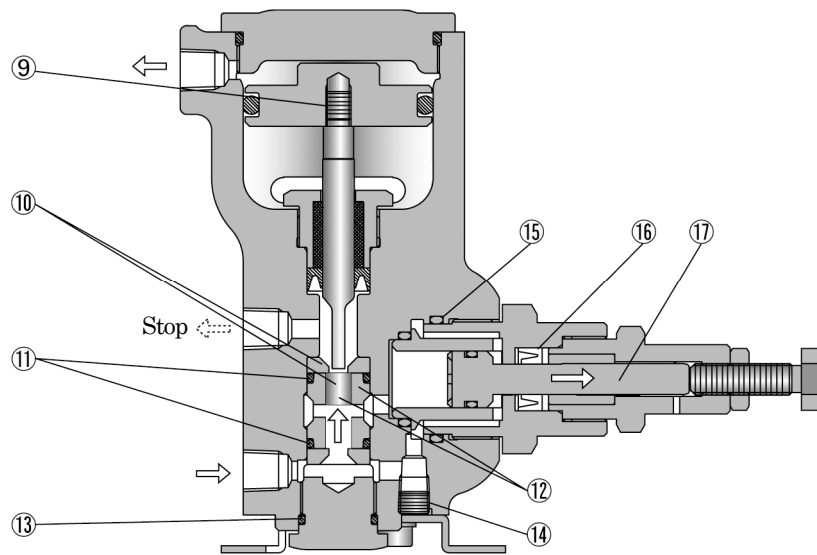

### <Problem>

- Material leak occurs in outlet port.
- Material leaks out.
- Material in outlet doesn't flow back after metering valve is closed.

### <Possible Cause>

- ⑨ Piston rod is loose and pushes valve.
- ⑩ Seat or valve is damaged or worn out.
- ⑪ O ring is damaged or worn out.
- ⑫ Joint of valve and sleeve is loose.
- ⑬ O ring is damaged or worn out.
- ⑭ Plug is loose.
- ⑮ O ring is damaged or worn out.
- ⑯ Packing is damaged or worn out.
- ⑰ Piston is damaged or worn out.

### <Solution>

- Apply adhesive to threaded part and secure piston rod.
- Replace with a new one.
- Replace with a new one.
- Replace with a new one.
- Replace with a new one.
- Secure plug tightly.
- Replace with a new one.
- Replace with a new one.
- Replace with a new one.

## ⚠ CAUTION

- The life of a U-packing is reduced if the sleeve inside is severely damaged or clearance between the piston and rod has become too much. At the time of replacing the U-packing, be sure to check the sleeve and piston as well.
- When setting a shot volume, turn the adjustment screw with the outlet valve open. Once the exact value has been set, secure the screw with a locknut.



## PRECAUTION FOR USE

- Please contact the store you purchased the product or our business office if a metering error has happened soon even though it didn't occur at the beginning of use.
- When handling silicone grease, be sure to select a designated valve for silicone grease. If a grease or adhesive metering valve is used, seizure of a valve and sleeve will occur, resulting in malfunction of a metering valve.



## CAUTION

- The Packing(s) efficiency of the Metering Valves and the Cylinders for adhesive materials will be decreased by temperature change and/or aging degradation. You can adjust the Retainer and improve the Packing(s) efficiency without removing the Metering Cylinder from the valve body. If the Piston does not work properly or leakage occurs, please adjust the Retainer torque. Since there are similar Packings in the switching valve body, you can adjust them in the similar way.



## CAUTION

If material flows out continuously even after a metered shot has been dispensed, it may be caused by conditions of inlet or outlet lines or a procedure taken to restart operation after repair. Please follow the following recovery procedures.

- When using a metering valve for the first time including after repair, run the valve without connecting dispensing equipment, coupling, hose, or any other accessories to a material outlet. Keep running the valve until all trapped air inside a material supply pump, hose, pipe, and metering valve is expelled completely. Make sure that the valve is closed before making connection to the outlet.
- When material continuously flows out from dispensing equipment or an outlet of a secondary pipe, the outlet of the metering valve doesn't generally have a defect. In most of these cases, it is caused when a pipe line is too long or short or when material of a pipe is flexible. To solve this problem, repeat "Discharge" and "Standby" until continuous flow stops.

---

## 6. Disassembly and Assembly



## CAUTION

- Release residual pressure completely BEFORE disassembling metering valves.
- Wash the parts with wash oil and apply a thin layer of lithium grease BEFORE reassembling. Be extremely careful not to let dust and dirt attach to any of the parts.

## 6-1 Disassembly of metering valve

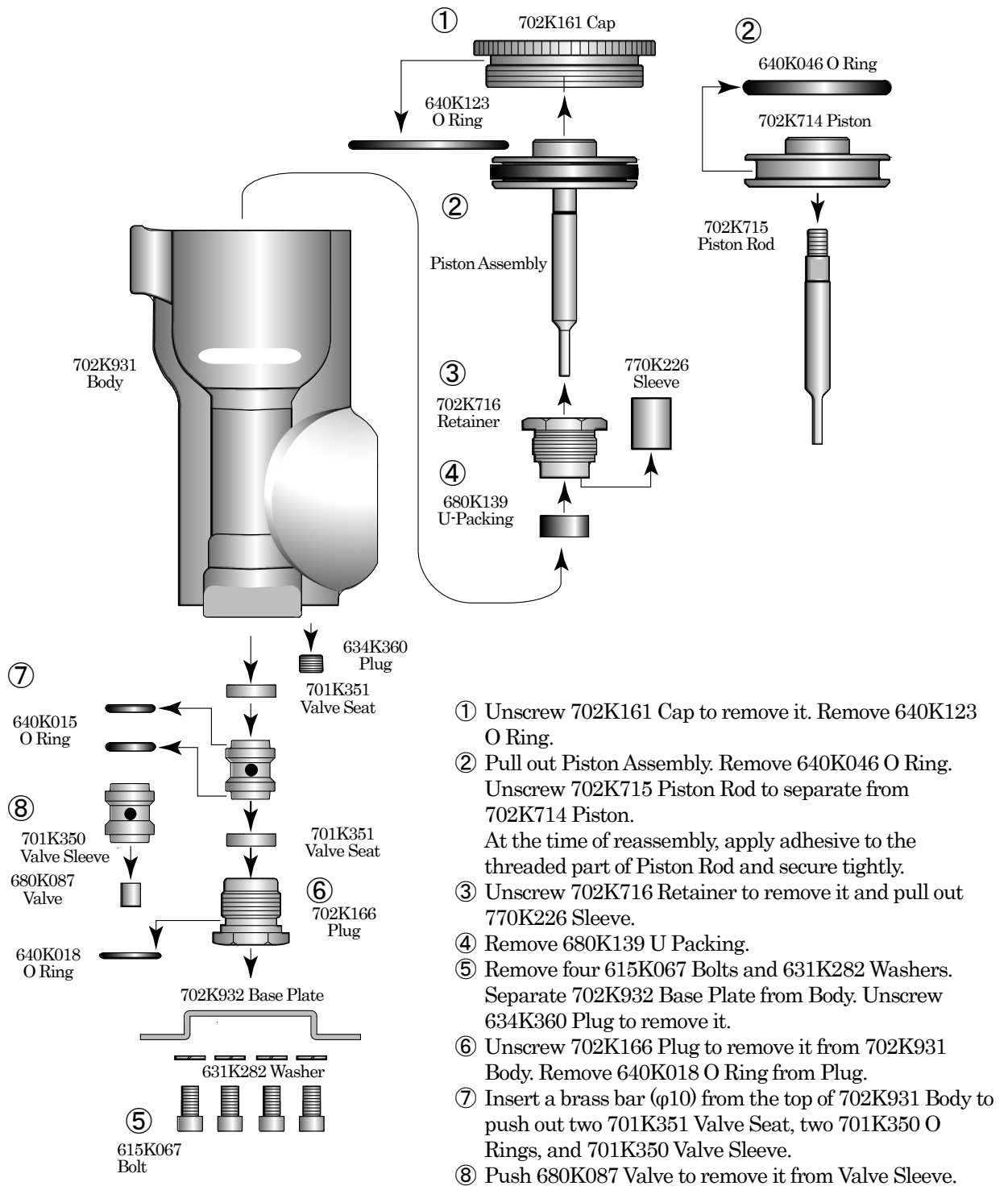

## 6-2 Disassembly of metering cylinder

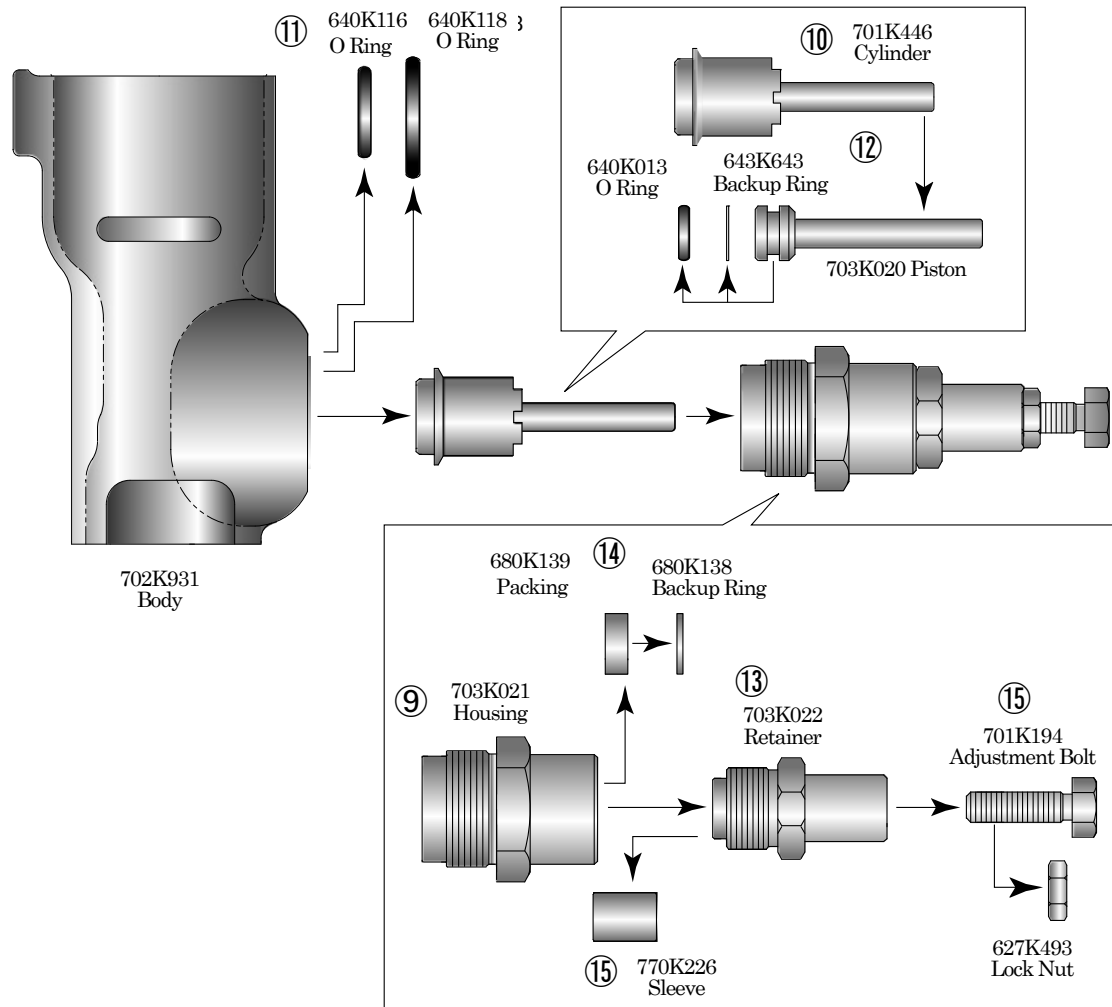

### CAUTION

- To reassemble, reverse procedure to disassembly.
- When reassembling the disassembled meter valve, be sure to replace O Rings and Packings with new ones at the same time as defective parts.
- The figure above shows a 5 mL grease metering valve. The other metering valves consist of mostly the same except sizes and shapes. (See [Product and Part List] for more details.) The structure of adhesive metering valves is also the same as the grease valves except that U-Packings (④ and ⑭) are changed to special parts made with fluorine resin and material of O Ring is changed from nitrile rubber to fluorine resin.

- ⑨ Unscrew 703K021 Housing to remove it from 702K931 Body.
- ⑩ Pull out 701K446 Cylinder from Body.
- ⑪ Remove 640K013 O Ring and 640K116 O Ring from Body.
- ⑫ Pull out 703K020 Piston from 701K446 Cylinder. Remove 640K013 O Ring and 643K643 Backup Ring.
- ⑬ Unscrew 703K022 Retainer to remove it from 703K021 Housing.
- ⑭ Remove 680K139 Packing and 680K138 Backup Ring from Housing.
- ⑮ Remove 701K194 Screw and 627K493 Lock Nut from Retainer and pull out 770K226 Sleeve.

## 7. Product and Part List for Grease Metering Valve

### 7-1 Metering Valve

#### 0.5 mL-50 mL Metering Valve (Standard Model)

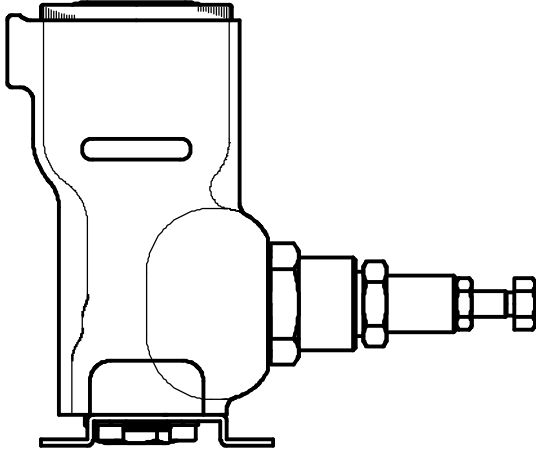

MODEL LIST

Size	Product No.	Switching Valve	Cylinder
0.5 mL	686405	800K507	801K631
1 mL	686406	800K507	800K856
3 mL	686407	800K507	800K857
5 mL	686408	800K507	800K858
10 mL	686409	800K507	800K859
20 mL	686410	800K507	800K860
50 mL	686411	800K927	800K493

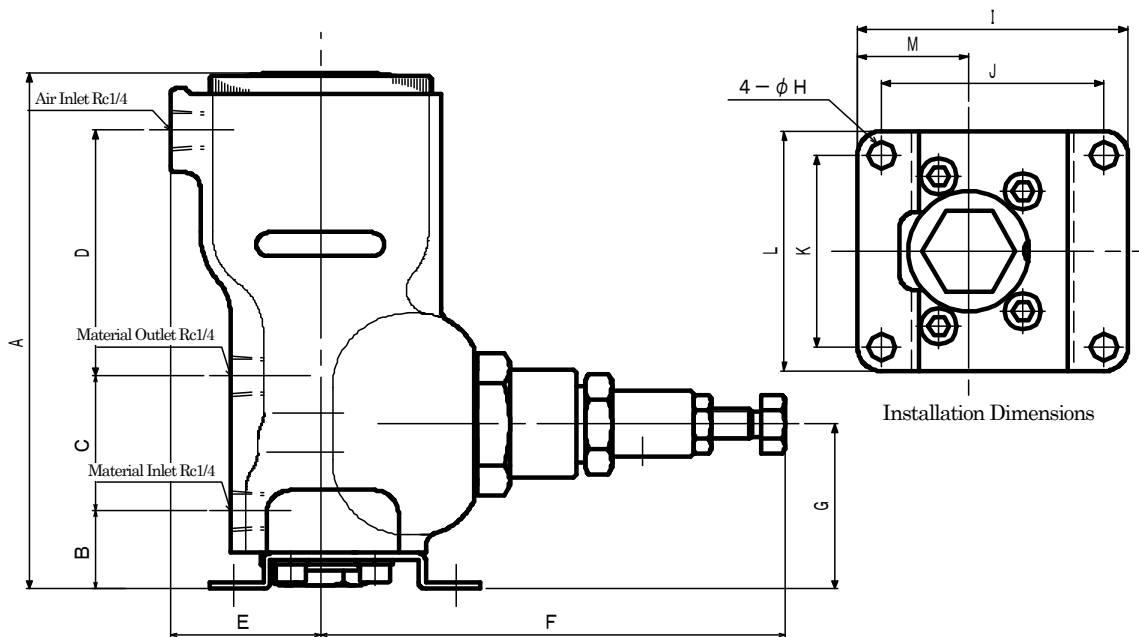

DIMENSIONS

Size	A	B	C	D	E	F*	G	H	I	J	K	L	M
0.5 mL	172	26	45	82	50	128	55	Φ 9	90	74	64	80	37
1 mL	172	26	45	82	50	118.5	55	Φ 9	90	74	64	80	37
3 mL	172	26	45	82	50	133.5	55	Φ 9	90	74	64	80	37
5 mL	172	26	45	82	50	154.5	55	Φ 9	90	74	64	80	37
10 mL	172	26	45	82	50	186.5	55	Φ 9	90	74	64	80	37
20 mL	172	26	45	82	50	259.6	55	Φ 9	90	74	64	80	37
50 mL	202	40	45	94	72	285.5	70	Φ 9	100	84	84	100	40

\*set at a maximum value

## 7-2 Switching Valve Body

### 800K507 Switching Valve Body

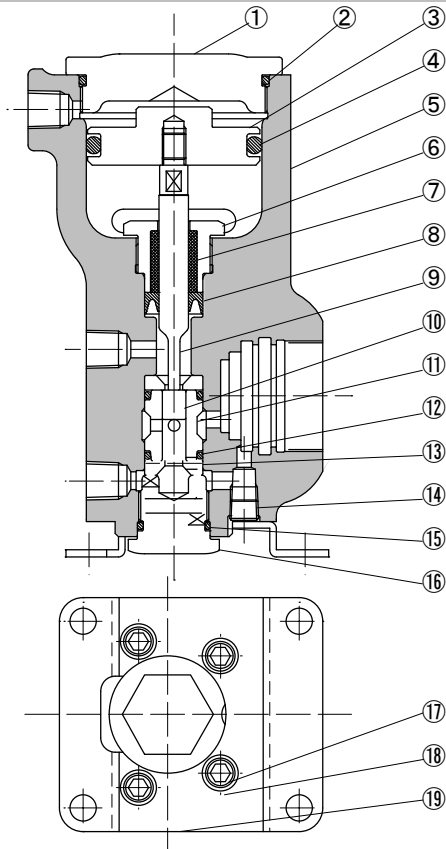

800K507 Switching Valve Body

No.	Parts No.	Description	Qty
1	702K161	Cap	1
2	640K123	O ring	1
3	702K714	Piston	1
4	640K046	O ring	1
5	702K931	Body	1
6	702K716	Retainer	1
7	770K226	Sleeve	1
8	680K139	Packing	1
9	702K715	Piston rod	1
10	680K087	Valve	1
11	701K350	Valve sleeve	1
12	643K015	O ring	2
13	701K351	Valve seat	2
14	634K360	Plug	1
15	640K018	O ring	1
16	702K166	Plug	1
17	615K067	Bolt	4
18	631K282	Spring lock washer	4
19	702K932	Base plate	1

### 800K927 Switching Valve Body

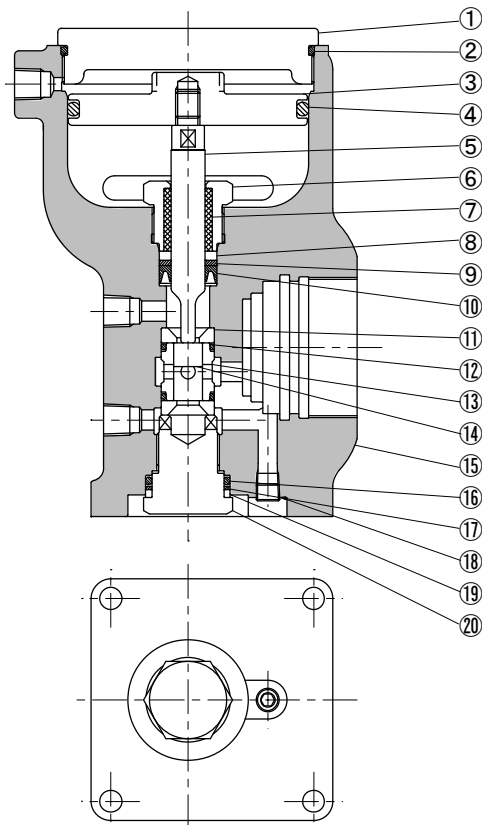

800K927 Switching Valve Body

No.	Parts No.	Description	Qty
1	703K285	Cylinder head	1
2	640K131	O ring	1
3	703K286	Piston	1
4	640K059	O ring	1
5	703K287	Piston rod	1
6	703K288	Gland retainer	1
7	770K300	Sleeve	1
8	703K293	Packing retainer	1
9	770K301	Back up ring	1
10	680K107	Packing	1
11	703K291	Valve seat	2
12	643K016	O ring	2
13	703K290	Valve sleeve	1
14	703K292	Valve	1
15	703K284	Body	1
16	640K117	O ring	1
17	643K747	Back up ring	1
18	634K360	Plug	1
19	703K294	Collar	1
20	703K289	Valve retainer	1

## 7-3 Grease Metering Cylinder

### 801K631 Metering Cylinder (0.5 mL)

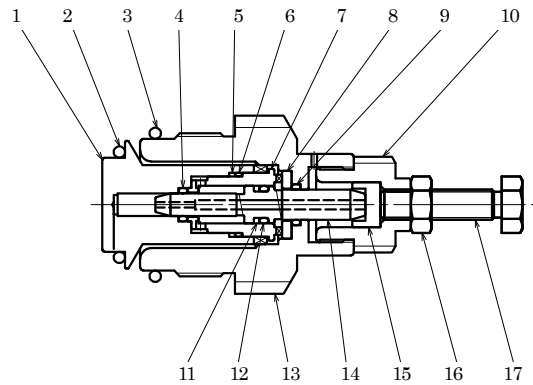

801K631 Metering Cylinder (0.5 mL)

No.	Parts No.	Description	Qty
1	705K206	Cylinder case	1
2	644K116	O ring	1
3	644K118	O ring	1
4	682K063	Seal	1
5	770K425	Back up ring	1
6	682K065	O ring	1
7	705K207	Cylinder	1
8	705K208	Packing gland	1
9	682K064	Seal	1
10	705K209	Retainer	1
11	645K634	Back up ring	1
12	640K004	O ring	1
13	705K210	Cylinder housing	1
14	705K211	Piston	1
15	705K212	Stopper	1
16	627K491	Lock nut	1
17	701K198	Adjustment bolt	1

### 800K856 Metering Cylinder (1 mL)

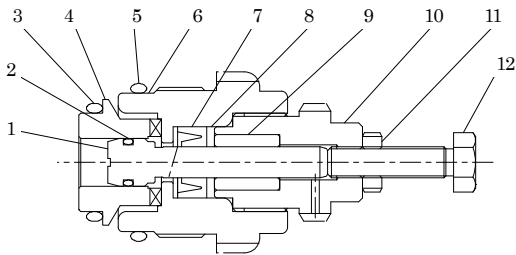

800K856 Metering Cylinder (1 mL)

No.	Parts No.	Description	Q'ty
1	703K014	Piston	1
2	644K006	O ring	1
3	644K116	O ring	1
4	701K450	Cylinder	1
5	644K118	O ring	1
6	703K015	Housing	1
7	680K185	Packing	1
8	680K328	Back up ring	1
9	770K285	Sleeve	1
10	703K016	Retainer	1
11	627K491	Lock nut	1
12	701K198	Adjustment bolt	1

### 800K857 Metering Cylinder (3 mL)

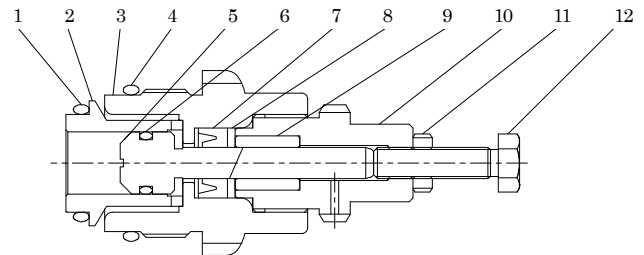

800K857 Metering Cylinder (3 mL)

No.	Parts No.	Description	Q'ty
1	644K116	O ring	1
2	701K354	Cylinder	1
3	703K018	Housing	1
4	644K118	O ring	1
5	703K017	Piston	1
6	644K011	O ring	1
7	680K185	Packing	1
8	680K328	Back up ring	1
9	770K285	Sleeve	1
10	703K019	Retainer	1
11	627K491	Lock nut	1
12	701K198	Adjustment bolt	1

### 800K858 Metering Cylinder (5 mL)

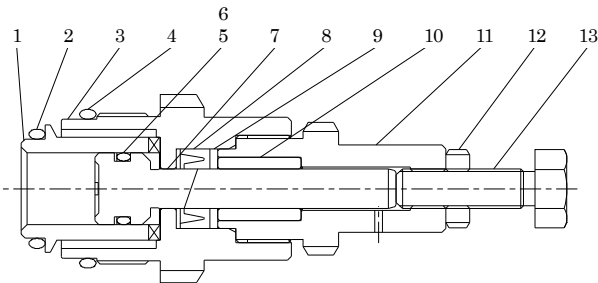

800K858 Metering Cylinder (5 mL)

No.	Parts No.	Description	Q'ty
1	701K446	Cylinder	1
2	644K116	O ring	1
3	703K021	Housing	1
4	644K118	O ring	1
5	644K013	O ring	1
6	645K643	Back up ring	1
7	703K020	Piston	1
8	680K139	Packing	1
9	680K138	Back up ring	1
10	770K226	Sleeve	1
11	703K022	Retainer	1
12	627K493	Lock nut	1
13	701K194	Adjustment bolt	1

### 800K859 Metering Cylinder (10 mL)

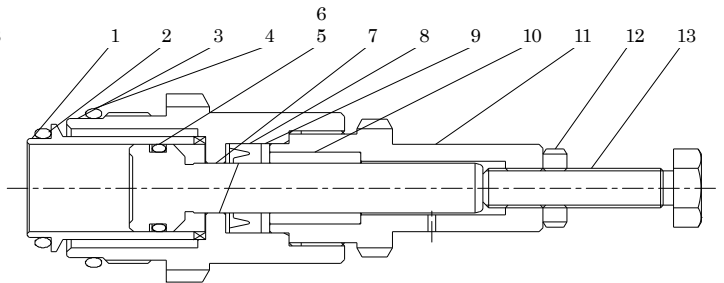

800K859 Metering Cylinder (10 mL)

No.	Parts No.	Description	Q'ty
1	701K429	Cylinder	1
2	644K116	O ring	1
3	703K024	Housing	1
4	644K118	O ring	1
5	644K016	O ring	1
6	645K646	Back up ring	1
7	703K023	Piston	1
8	680K238	Packing	1
9	770K268	Back up ring	1
10	770K236	Sleeve	1
11	703K025	Retainer	1
12	627K493	Lock nut	1
13	701K191	Adjustment bolt	1

## 800K860 Metering Cylinder (20 mL)

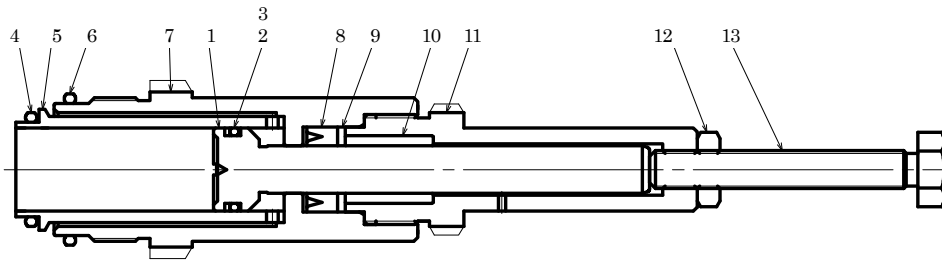

800K860 Metering Cylinder (20 mL)

No.	Parts No.	Description	Q'ty
1	703K026	Piston	1
2	644K016	O ring	1
3	645K646	Back up ring	1
4	644K116	O ring	1
5	701K931	Cylinder	1
6	644K118	O ring	1
7	703K027	Housing	1
8	680K238	Packing	1
9	770K268	Back up ring	1
10	770K236	Sleeve	1
11	703K028	Retainer	1
12	627K493	Lock nut	1
13	703K504	Adjustment bolt	1

## 800K493 Metering Cylinder (50 mL)

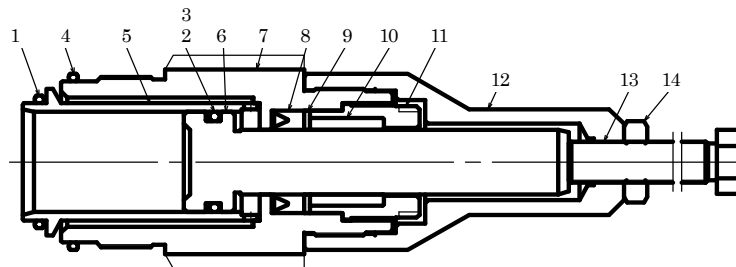

800K493 Metering Cylinder (50 mL)

No.	Parts No.	Description	Q'ty
1	643K119	O ring	1
2	644K026	O ring	1
3	645K656	Back up ring	1
4	643K122	O ring	1
5	701K890	Cylinder	1
6	702K110	Piston	1
7	702K088	Housing	1
8	680K106	Packing	1
9	770K210	Back up ring	1
10	770K211	Sleeve	1
11	702K090	Retainer	1
12	702K111	Cover	1
13	702K091	Adjustment bolt	1
14	627K496	Lock nut	1

## 7-4 Specifications

Product No.	686405	686406	686407	686408	686409	686410	686411
Model	KGK-401M	KGK-402M	KGK-404M	KGK-405M	KGK-406M	KGK-407M	KGK-408M
Applicable Material	Greases, High Viscosity Oils - Please contact us if you are going to use any material such as silicone grease or molybdenum disulfide grease which will affect the operation of a valve. - Any material which contains particles such as aggregate or fast drying type of material is NOT applicable. - Wetted parts in a metering valve are made of steel and aluminum alloy and seal parts are made of NBR and polyurethane. Make sure that material you are going to use is compatible with these parts.						
Capacity	0.5 mL	1 mL	3 mL	5 mL	10 mL	20 mL	50 mL
Shot Range	0.05-0.5 mL	0.2-1 mL	0.3-3 mL	2-5 mL	4-10 mL	8-20 mL	15-50 mL
Shot Accuracy	±2%						
Maximum Operating Pressure	20 MPa						
Withstanding pressure	30 MPa						
Supply Air Pressure	Maximum: 0.7 MPa Recommended: 0.4-0.5 MPa						
Operating Temperature	Room Temperature						
Weight	2.6 kg	2.5 kg	2.6 kg	2.6 kg	2.8 kg	3.0 kg	7.9 kg

NOTE: Available material viscosity will vary according to use condition.

## 8. Product and Part List for Grease Metering Valve with Sensor

### 8-1 Metering Valve with Sensor

#### 0.5 mL-50 mL Metering Valve (Standard Model)

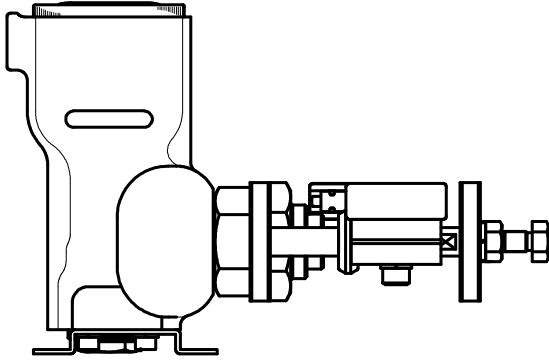

MODEL LIST

Size	Product No.	Switching Valve	Cylinder
0.5 mL	686418	800K507	801K637
1 mL	686419	800K507	800K891
3 mL	686420	800K507	800K903
5 mL	686421	800K507	800K474
10 mL	686422	800K507	800K485
20 mL	686423	800K927	800K484
50 mL	686424	800K927	800K486

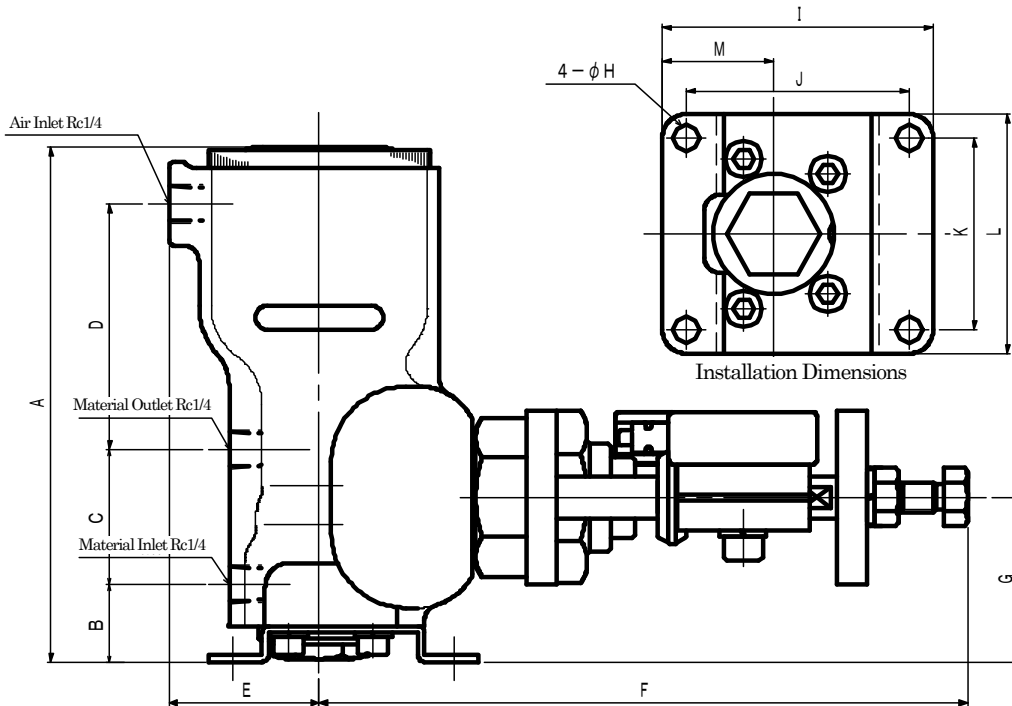

DIMENSIONS

Size	A	B	C	D	E	F*	G	H	I	J	K	L	M
0.5 mL	172	26	45	82	50	176.5	55	Φ 9	90	74	64	80	37
1 mL	172	26	45	82	50	135	55	Φ 9	90	74	64	80	37
3 mL	172	26	45	82	50	170	55	Φ 9	90	74	64	80	37
5 mL	172	26	45	82	50	196.5	55	Φ 9	90	74	64	80	37
10 mL	172	26	45	82	50	215	55	Φ 9	90	74	64	80	37
20 mL	202	40	45	94	72	259.3	70	Φ 9	100	84	84	100	40
50 mL	202	40	45	94	72	326	70	Φ 9	100	84	84	100	40

\*set at a maximum value

## 8-2 Switching Valve Body with Sensor

### 800K507 Switching Valve Body

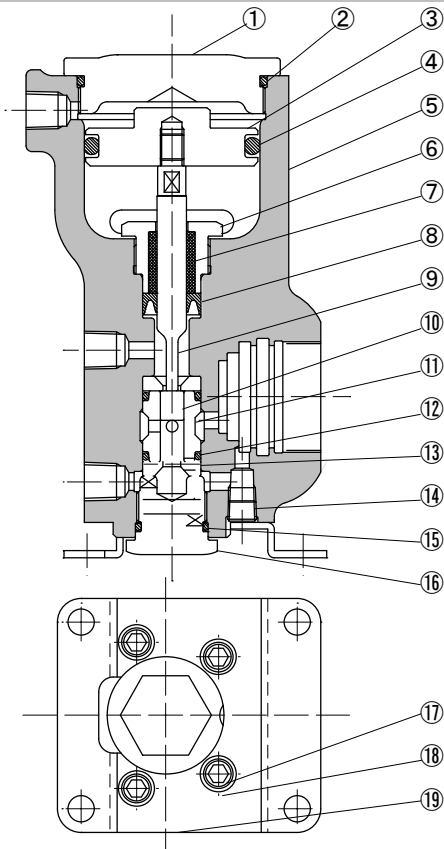

800K507 Switching Valve Body

No.	Parts No.	Description	Q'ty
1	702K161	Cap	1
2	640K123	O ring	1
3	702K714	Piston	1
4	640K046	O ring	1
5	702K931	Body	1
6	702K716	Retainer	1
7	770K226	Sleeve	1
8	680K139	Packing	1
9	702K715	Piston rod	1
10	680K087	Valve	1
11	701K350	Valve sleeve	1
12	643K015	O ring	2
13	701K351	Valve seat	2
14	634K360	Plug	1
15	640K018	O ring	1
16	702K166	Plug	1
17	615K067	Bolt	4
18	631K282	Spring lock washer	4
19	702K932	Base plate	1

### 800K927 Switching Valve Body

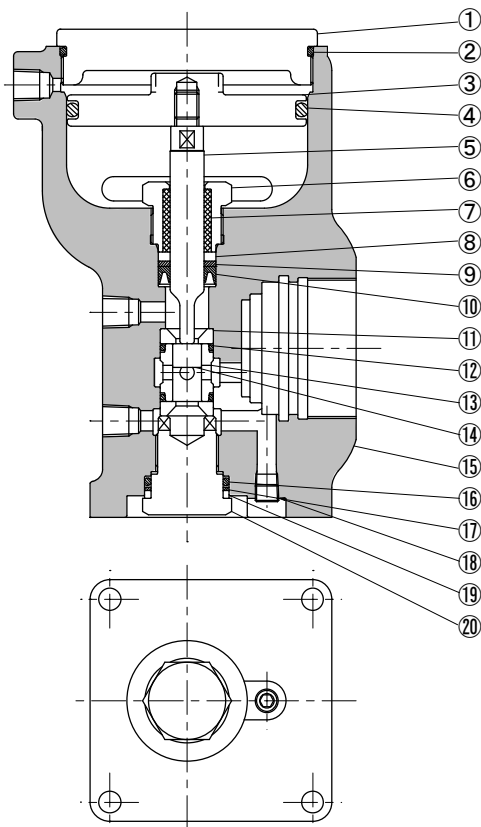

800K927 Switching Valve Body

No.	Parts No.	Description	Q'ty
1	703K285	Cylinder head	1
2	640K131	O ring	1
3	703K286	Piston	1
4	640K059	O ring	1
5	703K287	Piston rod	1
6	703K288	Gland retainer	1
7	770K300	Sleeve	1
8	703K293	Packing retainer	1
9	770K301	Back up ring	1
10	680K107	Packing	1
11	703K291	Valve seat	2
12	643K016	O ring	2
13	703K290	Valve sleeve	1
14	703K292	Valve	1
15	703K284	Body	1
16	640K117	O ring	1
17	643K747	Back up ring	1
18	634K360	Plug	1
19	703K294	Collar	1
20	703K289	Valve retainer	1

### 8-3 Metering Valve with Sensor

#### 801K637 Metering Cylinder with Sensor (0.5 mL)

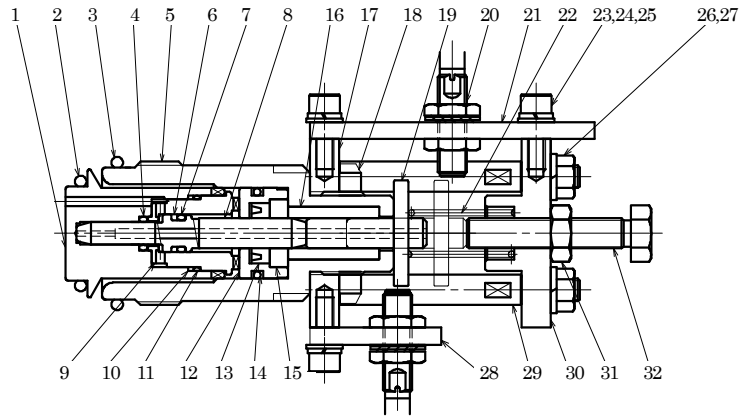

801K637 Metering Cylinder with Sensor (0.5 mL)

No.	Parts No.	Description	Qty	No.	Parts No.	Description	Qty
1	705K228	Cylinder case	1	17	703K191	Flange A	1
2	644K116	O ring	1	18	703K186	Lock nut	1
3	644K118	O ring	1	19	705K233	Spring guide	1
4	682K063	Seal	1	20	680K858	Sensor	2
5	705K229	Housing	1	21	705K234	Switch holder A	1
6	645K634	Back up ring	1	22	704K976	Coil spring	1
7	640K004	O ring	1	23	615K053	Bolt	4
8	705K230	Piston	1	24	631K281	Spring lock washer	4
9	705K231	Cylinder A	1	25	631K051	Plain washer	4
10	770K432	Back up ring	1	26	627K027	Nut	4
11	683K315	O ring	1	27	631K282	Spring lock washer	4
12	705K232	Cylinder B	1	28	705K235	Switch holder B	1
13	680K198	Packing	1	29	705K236	Stud	4
14	640K017	O ring	1	30	705K237	Flange B	1
15	705K661	Back up ring	1	31	627K491	Lock nut	1
16	770K298	Sleeve	1	32	611K533	Adjustment bolt	1

## 800K891 Metering Cylinder with Sensor (1 mL)

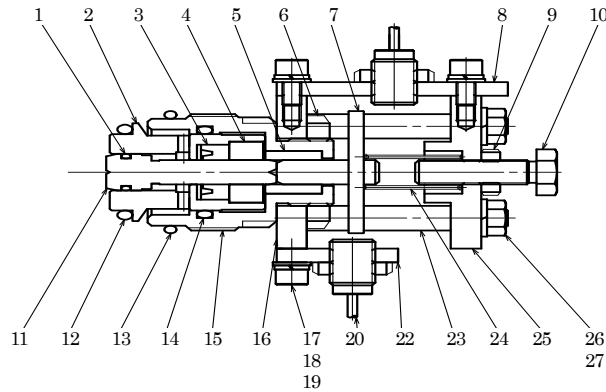

800K891 Metering Cylinder with Sensor (1 mL)

No.	Parts No.	Description	Q'ty	No.	Parts No.	Description	Q'ty	No.	Parts No.	Description	Q'ty
1	644K006	O ring	1	11	703K189	Piston	1	21			
2	703K185	Cylinder	1	12	644K116	O ring	2	22	703K192	Switch holder B	1
3	680K185	Packing	1	13	644K118	O ring	1	23	703K193	Stud	4
4	770K296	Back up ring	1	14				24	703K194	Coil spring	1
5	770K297	Sleeve	1	15	703K190	Housing	1	25	703K195	Flange B	1
6	703K186	Lock nut	1	16	703K191	Flange A	1	26	627K027	Nut	4
7	703K187	Spring guide	1	17	615K052	Bolt	4	27	631K282	Spring lock washer	4
8	703K188	Switch holder A	1	18	631K281	Spring lock washer	4				
9	627K491	Lock nut	1	19	631K051	Plain washer	4				
10	701K198	Adjustment bolt	1	20	681K800	Sensor	2				

## 800K903 Metering Cylinder with Sensor (3 mL)

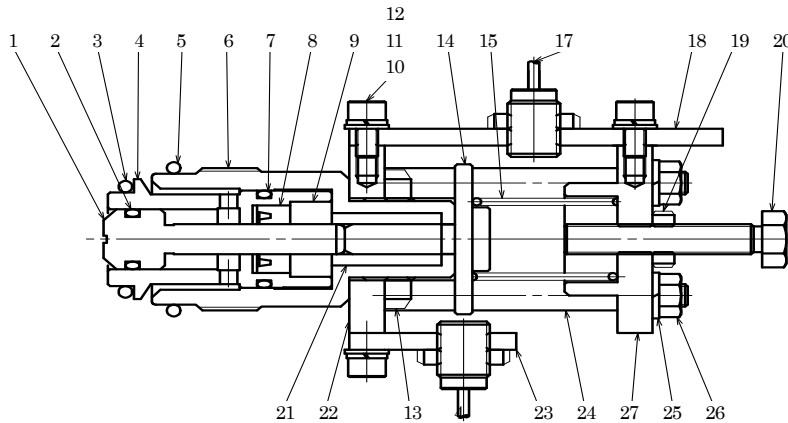

800K903 Metering Cylinder with Sensor (3 mL)

No.	Parts No.	Description	Q'ty	No.	Parts No.	Description	Q'ty	No.	Parts No.	Description	Q'ty
1	703K231	Piston	1	11	631K281	Spring lock washer	4	21	770K298	Sleeve	1
2	644K011	O ring	1	12	631K051	Plain washer	4	22	703K191	Flange A	1
3	640K116	O ring	1	13	703K186	Lock nut	1	23	703K237	Switch holder B	1
4	703K232	Cylinder	1	14	703K234	Spring guide	1	24	703K238	Stud	4
5	640K118	O ring	1	15	703K235	Coil spring	1	25	627K027	Nut	4
6	703K233	Housing	1	16				26	631K282	Spring lock washer	4
7	640K019	O ring	1	17	681K800	Sensor	2	27	703K239	Flange B	1
8	680K185	Packing	1	18	703K236	Switch holder A	1				
9	770K296	Back up ring	1	19	627K491	Lock nut	1				
10	615K052	Bolt	4	20	611K533	Adjustment bolt	1				

## 800K474 Metering Cylinder with Mechanical Switch (5 mL)

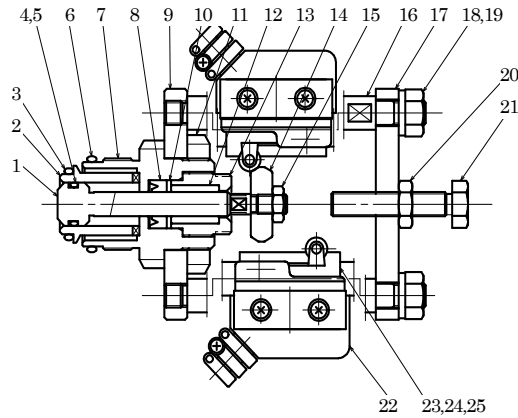

800K474 Metering Cylinder with Mechanical Switch (5 mL)

No.	Parts No.	Description	Qty	No.	Parts No.	Description	Qty	No.	Parts No.	Description	Qty
1	702K700	Piston	1	11	680K138	Back up ring	1	21	702K697	Adjustment bolt	1
2	701K446	Cylinder	1	12	770K226	Sleeve	1	22	800K509	Switch assembly	2
3	640K116	O ring	1	13	702K702	Retainer	1	23	702K083	Sensor guide	2
4	644K013	O ring	1	14	702K703	Switch dog	1	24	615K107	Bolt	2
5	645K643	Back up ring	1	15	627K460	Lock nut	1	25	631K285	Spring lock washer	2
6	640K118	O ring	1	16	702K704	Stud	2				
7	702K701	Housing	1	17	702K696	Flange B	1				
8	670K139	Packing	1	18	627K031	Nut	2				
9	702K693	Flange A	1	19	631K287	Spring lock washer	2				
10	702K694	Lock nut	1	20	627K493	Lock nut	1				

## 800K485 Metering Cylinder with Mechanical Switch (10 mL)

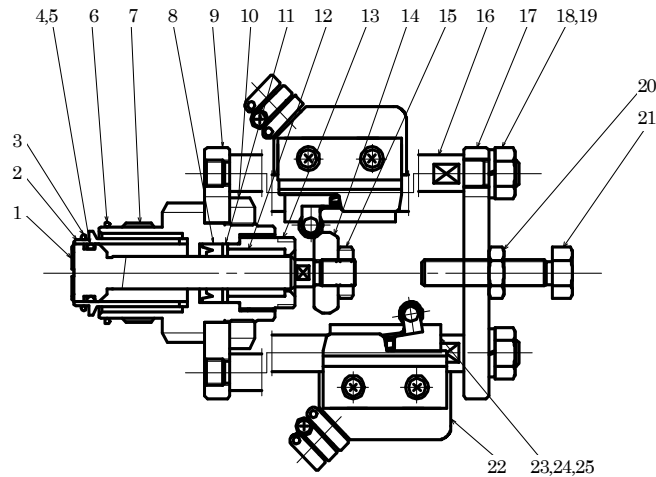

800K485 Metering Cylinder with Mechanical Switch (10 mL)

No.	Parts No.	Description	Qty	No.	Parts No.	Description	Qty	No.	Parts No.	Description	Qty
1	702K691	Piston	1	11	770K268	Back up ring	1	21	702K697	Adjustment bolt	1
2	701K429	Cylinder	1	12	770K236	Sleeve	1	22	800K509	Switch assembly	2
3	640K116	O ring	1	13	702K698	Retainer	1	23	702K083	Sensor guide	2
4	644K016	O ring	1	14	702K699	Switch dog	1	24	615K107	Bolt	2
5	645K646	Back up ring	1	15				25	631K285	Spring lock washer	2
6	640K118	O ring	1	16	702K695	Stud	2				
7	702K692	Housing	1	17	702K696	Flange B	1				
8	680K238	Packing	1	18	627K031	Nut	2				
9	702K693	Flange A	1	19	631K287	Spring lock washer	2				
10	702K694	Lock nut	1	20	627K493	Lock nut	2				

## 800K484 Metering Cylinder with Mechanical Switch (20 mL)

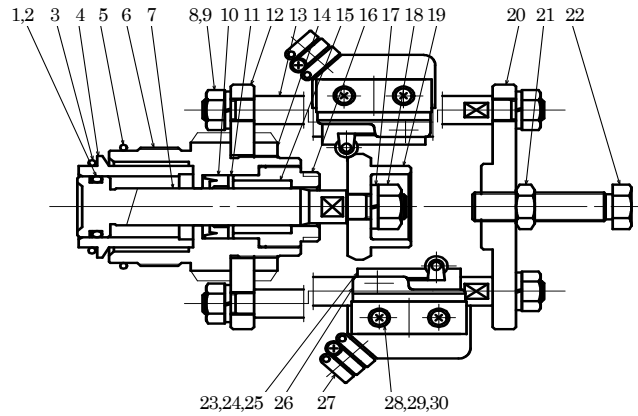

800K484 Metering Cylinder with Mechanical Switch (20 mL)

No.	Parts No.	Description	Qty	No.	Parts No.	Description	Qty	No.	Parts No.	Description	Qty
1	644K022	O ring	1	11	770K208	Back up ring	1	21	627K496	Lock nut	1
2	645K652	Back up ring	1	12	702K076	Flange A	1	22	702K082	Adjustment bolt	1
3	643K119	O ring	1	13	702K077	Stud	1	23	702K083	Sensor guide	2
4	702K073	Cylinder	1	14	702K078	Lock nut	1	24	615K107	Nut	2
5	643K122	O ring	1	15	770K209	Sleeve	1	25	631K285	Spring lock washer	2
6	702K074	Cylinder housing	1	16	702K079	Retainer	1	26	680K006	Microswitch	2
7	702K075	Piston	1	17	631K289	Spring lock washer	1	27	680K171	Switch cover	2
8	627K031	Nut	6	18	627K033	Nut	1	28	602K249	Screw	4
9	631K287	Spring lock washer	6	19	702K080	Switch dog	1	29	631K278	Spring lock washer	4
10	680K104	Packing	1	20	702K081	Flange B	1	30	631K048	Plain washer	4

## 800K486 Metering Cylinder with Mechanical Switch (50 mL)

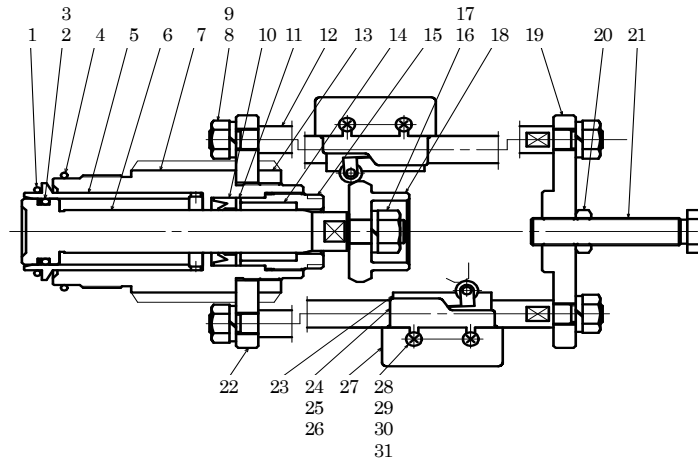

800K486 Metering Cylinder with Mechanical Switch (50 mL)

No.	Parts No.	Description	Qty	No.	Parts No.	Description	Qty	No.	Parts No.	Description	Qty
1	643K119	O ring	1	11	770K210	Back up ring	1	21	702K091	Adjustment bolt	1
2	644K026	O ring	1	12	702K089	Stud	3	22	702K076	Flange A	1
3	643K656	Back up ring	1	13	702K078	Lock nut	1	23	702K083	Sensor guide	2
4	643K122	O ring	1	14	770K211	Sleeve	1	24	615K107	Bolt	2
5	701K890	Cylinder	1	15	702K090	Retainer	1	25	631K285	Spring lock washer	2
6	702K087	Piston	1	16	627K033	Nut	1	26	680K006	Microswitch	2
7	702K088	Cylinder housing	1	17	631K289	Spring lock washer	1	27	680K007	Terminal cover	2
8	627K031	Nut	6	18	702K080	Switch dog	1	28	680K105	Switch cover	2
9	631K287	Spring lock washer	6	19	702K081	Flange B	1	29	602K249	Screw	4
10	680K106	Packing	1	20	627K496	Lock nut	1	30	631K278	Spring lock washer	4
								31	631K048	Spring lock washer	4

## 8-4 Specifications

Product No.	686418	686419	686420	686421	686422	686423	686424
Model	KGK-401MS	KGK-402MS	KGK-404MS	KGK-405MS	KGK-406MS	KGK-407MS	KGK-408MS
Applicable Material	Greases, High Viscosity Oils - Please contact us if you are going to use any material such as silicone grease or molybdenum disulfide grease which will affect the operation of a valve. - Any material which contains particles such as aggregate or fast drying type of material is NOT applicable. - Wetted parts in a metering valve are made of steel and aluminum alloy and seal parts are made of NBR and polyurethane. Make sure that material you are going to use is compatible with these parts.						
Capacity	0.5 mL	1 mL	3 mL	5 mL	10 mL	20 mL	50 mL
Shot Range	0.05-0.5 mL	0.2-1 mL	0.3-3 mL	2-5 mL	4-10 mL	8-2 mL	15-50 mL
Shot Accuracy	±2%						
Maximum Operating Pressure	20 MPa						
Withstanding pressure	30 MPa						
Supply Air Pressure	Maximum: 0.7 MPa Recommended: 0.4-0.5 MPa						
Operating Temperature	Room Temperature						
Weight	3.2 kg	3.0 kg	3.2 kg	4.2 kg	4.3 kg	9.4 kg	10.2 kg

NOTE: Available material viscosity will vary according to use condition.

## 9. Product and Part List for Adhesive Metering Valve

### 9-1 Adhesive Metering Valve

#### 1mL-50 mL Metering Valve (Fluorine Resin Model)

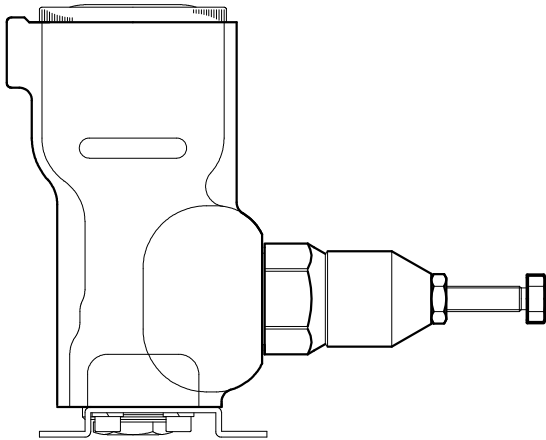

MODEL LIST

Size	Product No.	Switching Valve	Cylinder
1 mL	686412	800K416	800K376
3 mL	686413	800K416	800K377
5 mL	686414	800K416	800K378
10 mL	686415	800K416	800K379
20 mL	686416	800K416	800K572
50 mL	686417	800K942	800K463

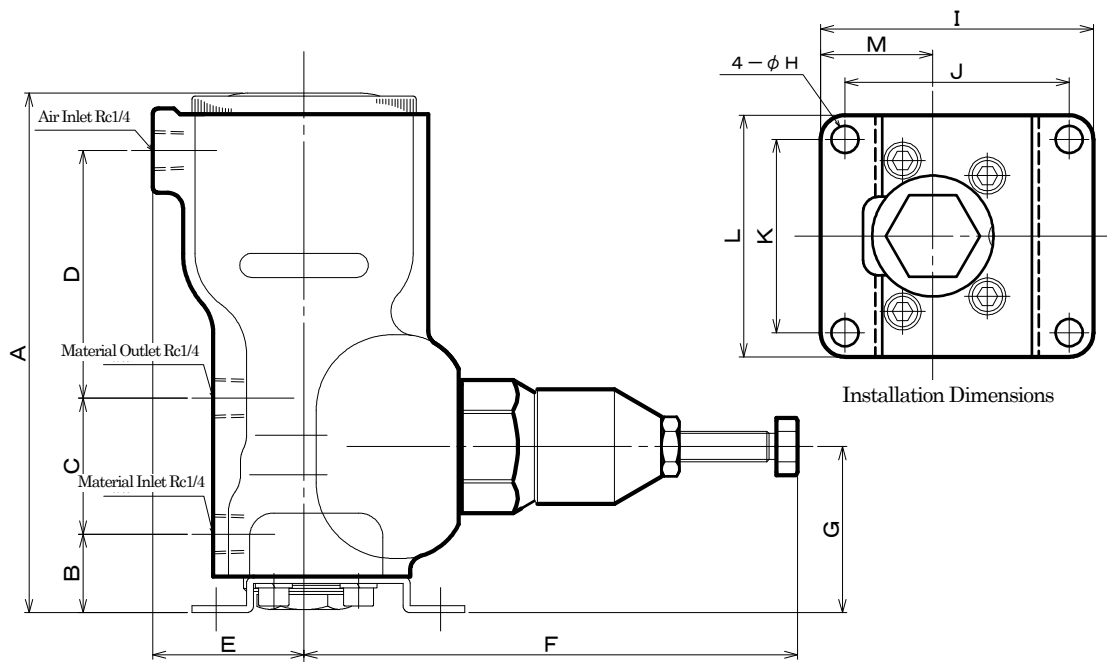

DIMENSIONS

Size	A	B	C	D	E	F*	G	H	I	J	K	L	M
1 mL	172	26	45	82	50	104	55	Φ 9	90	74	64	80	37
3 mL	172	26	45	82	50	118	55	Φ 9	90	74	64	80	37
5 mL	172	26	45	82	50	146	55	Φ 9	90	74	64	80	37
10 mL	172	26	45	82	50	163	55	Φ 9	90	74	64	80	37
20 mL	172	26	45	82	50	211.7	55	Φ 9	90	74	64	80	37
50 mL	202	40	45	94	72	261	70	Φ 9	100	84	84	100	40

\*set at a maximum value

## 9-2 Switching Valve Body

### 800K416 Switching Valve Body

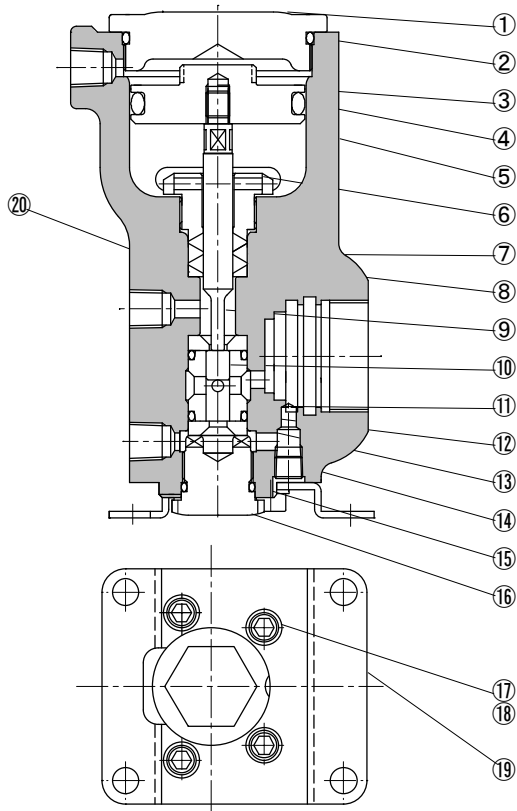

800K416 Switching Valve Body

No.	Parts No.	Description	Qty
1	702K161	Cap	1
2	640K123	O ring	1
3	702K714	Piston	1
4	640K046	O ring	1
5	702K931	Body	1
6	702K718	Retainer	1
7	770K270	Packing	1
8	770K269	Packing	2
9	702K715	Piston rod	1
10	680K087	Valve	1
11	701K350	Valve sleeve	1
12	643K015	O ring	2
13	701K351	Valve seat	2
14	634K360	Plug	1
15	640K018	O ring	1
16	702K166	Plug	1
17	615K067	Bolt	4
18	631K282	Spring lock washer	4
19	702K932	Base plate	1
20	702K719	Packing retainer	1

### 800K942 Switching Valve Body

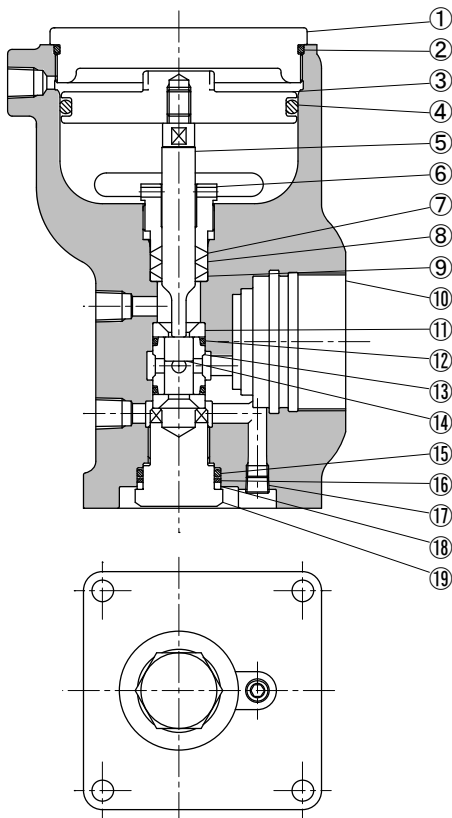

801K942 Switching Valve Body

No.	Parts No.	Description	Qty
1	703K285	Cylinder head	1
2	640K131	O ring	1
3	703K286	Piston	1
4	640K059	O ring	1
5	703K287	Piston rod	1
6	703K338	Gland retainer	1
7	770K215	Packing	2
8	770K216	Packing	1
9	702K164	Packing retainer	1
10	703K284	Body	1
11	703K291	Valve seat	2
12	643K016	O ring	2
13	703K290	Valve sleeve	1
14	703K292	Valve	1
15	640K117	O ring	1
16	643K747	Back up ring	1
17	636K360	Plug	1
18	703K294	Collar	1
19	703K289	Valve retainer	1

## 9-3 Metering Cylinder

800K376 Metering Cylinder (1 mL)

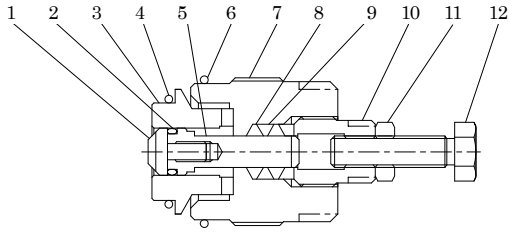

800K376 Metering Cylinder (1 mL)

No.	Parts No.	Description	Q'ty
1	701K449	Packing retainer	1
2	643K006	O ring	1
3	701K450	Cylinder	1
4	643K116	O ring	1
5	701K452	Piston	1
6	643K118	O ring	1
7	701K451	Housing	1
8	770K111	Packing	2
9	770K113	Packing	1
10	702K141	Retainer	1
11	627K491	Lock nut	1
12	701K198	Adjustment bolt	1

800K377 Metering Cylinder (3 mL)

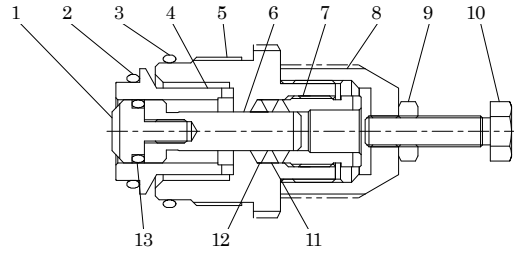

800K377 Metering Cylinder (3 mL)

No.	Parts No.	Description	Q'ty
1	701K353	Packing retainer	1
2	643K116	O ring	1
3	643K118	O ring	1
4	701K354	Cylinder	1
5	701K355	Housing	1
6	701K356	Piston	1
7	701K357	Retainer	1
8	701K358	Cover	1
9	627K491	Lock nut	1
10	701K198	Adjustment bolt	1
11	770K125	Packing	1
12	770K112	Packing	2
13	643K011	O ring	1

800K378 Metering Cylinder (5 mL)

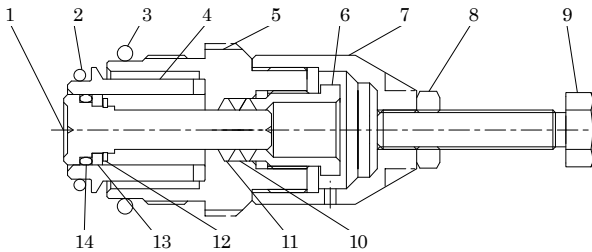

800K378 Metering Cylinder (5 mL)

No.	Parts No.	Description	Q'ty
1	701K455	Piston	1
2	643K116	O ring	1
3	643K118	O ring	1
4	701K446	Cylinder	1
5	701K456	Housing	1
6	701K453	Retainer	1
7	701K457	Cover	1
8	627K493	Lock nut	1
9	701K191	Adjustment bolt	1
10	770K125	Packing	1
11	770K112	Packing	2
12	630K582	Retaining ring	1
13	701K458	Washer	1
14	643K013	O ring	1

800K379 Metering Cylinder (10 mL)

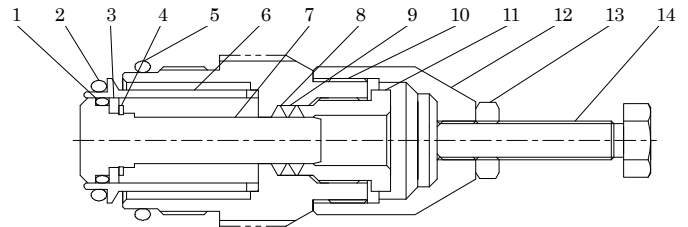

800K379 Metering Cylinder (10 mL)

No.	Parts No.	Description	Q'ty
1	643K016	O ring	1
2	643K116	O ring	1
3	701K463	Washer	1
4	630K584	Retaining ring	1
5	643K118	O ring	1
6	701K429	Cylinder	1
7	701K460	Piston	1
8	770K131	Packing	2
9	770K130	Packing	1
10	701K461	Housing	1
11	701K459	Packing retainer	1
12	701K457	Cover	1
13	627K493	Lock nut	1
14	701K191	Adjustment bolt	1

### 800K572 Metering Cylinder (20 mL)

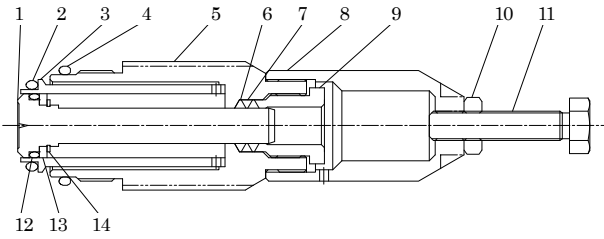

### 800K463 Metering Cylinder (50 mL)

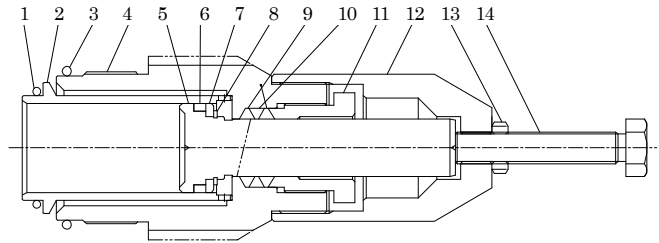

#### 800K572 Metering Cylinder (20 mL)

No.	Parts No.	Description	Q'ty
1	702K729	Piston	1
2	643K116	O ring	1
3	701K931	Cylinder	1
4	643K118	O ring	1
5	702K730	Housing	1
6	770K131	Packing	1
7	770K130	Packing	1
8	702K731	Cover	1
9	701K459	Packing retainer	1
10	627K493	Lock nut	1
11	701K191	Adjustment bolt	1
12	643K016	O ring	1
13	701K463	Washer	1
14	630K584	Retaining ring	1

#### 800K463 Metering Cylinder (50 mL)

No.	Parts No.	Description	Q'ty
1	643K119	O ring	1
2	701K890	Cylinder	1
3	643K122	O ring	1
4	701K891	Cylinder housing	1
5	701K892	Piston	1
6	770K185	Packing	1
7	701K893	Packing retainer	1
8	631K866	Retaining ring	1
9	770K186	Packing	1
10	770K187	Packing	1
11	701K894	Retainer	1
12	701K895	Tail cover	1
13	627K493	Lock nut	1
14	701K889	Adjustment bolt	1

## 9-4 Specifications

Product No.	686412	686413	686414	686415	686416	686417
Model	KGK-402T	KGK-404T	KGK-405T	KGK-406T	KGK-407T	KGK-408T
Applicable Material	Adhesive - Any material which contains particles such as aggregate or fast drying type of material is NOT applicable. - Wetted parts in a metering valve are made of steel and aluminum alloy and seal parts are made of fluorine resin. Make sure that material you are going to use is compatible with these parts.					
Capacity	1 mL	3 mL	5 mL	10 mL	20 mL	50 mL
Shot Range	0.2-1 mL	0.3-3 mL	2-5 mL	4-10 mL	8-20 mL	15-50 mL
Shot Accuracy	±2%					
Maximum Operating Pressure	20 MPa					
Withstanding pressure	30 MPa					
Supply Air Pressure	Maximum: 0.7 MPa Recommended: 0.4-0.5 MPa					
Operating Temperature	Room Temperature					
Weight	2.5 kg	2.6 kg	2.6 kg	2.8 kg	3.0 kg	7.9 kg

NOTE: Available material viscosity will vary according to use condition.

## 10. Limited Warranty

If an abnormality occurs during normal operation in accordance with the operating instructions and other operating cautions within the warranty period (12 months after date of purchase) that can be attributed to a manufacturing defect, the defective parts of this product will be serviced or the product will be replaced free of charge. However, this warranty will not cover compensation for incidental damage or any malfunction listed below.

### 1. Warranty period

This warranty will be valid for a period of 12 months after the date of purchase.

### 2. Warranty

If, during the warranty period, any of the material of the genuine parts of this product or the workmanship of this product is found defective, and is so verified by our company, the servicing cost will be fully born by our company.

### 3. Exclusion

Even during the warranty period, this warranty does not cover the following:

- 1) Malfunction arising from use of parts other than manufacturer-specified genuine parts
- 2) Malfunction arising from misuse or operating errors, or lack of storage or maintenance care
- 3) Malfunction arising from use with a fluid that may cause corrosion, inflation or dissolution of the component parts of the product
- 4) Irregularity arising from repair made by other than by our firm, our regional office, dealer or authorized service personnel
- 5) Malfunction arising from modification of the product by other than authorized service personnel
- 6) Wear and tear of parts that must be regularly replaced in the course of normal operation, such as packings, O-rings, balls, and valve seats
- 7) Malfunction and/or damage due to transportation, moving or droppage of the product after purchase
- 8) Malfunction and/or damage due to fire, earthquake, flood or other force majeure
- 9) Malfunction arising from use of compressed air that contains impurities or excessive moisture, or use of gases or fluids other than the specified compressed air
- 10) Malfunction arising from use with a fluid that causes excessive abrasion or use of lubricating oil other than that specified for this product

Furthermore, this warranty does not cover the rubber parts, or other parts that are subject to wear in normal operation, used in this product and its accessories.

### 4. Parts

Parts for this product will be kept available for 5 years after discontinuation of production. Once 5 years have elapsed after close of production, availability of parts for this product cannot be guaranteed.



## **YAMADA CORPORATION**

### **INTERNATIONAL DEPARTMENT**

1-1-3, Minami-Magome, Ota ku, Tokyo, 143-8504, Japan

PHONE : +81-(0)3-3777-0241

FAX : +81-(0)3-3777-0584

E-mail : intl@yamadacorp.co.jp

Web : www.yamadacorp.co.jp

## **YAMADA (THAILAND) CO., LTD**

41/79 Moo 6, Bangcha-long, Bangplee, Sumutprakarn 10540, Thailand

PHONE : +66-(0)2-130-0990

FAX : +66-(0)2-130-0993

E-mail : sales@yamada-th.com